

CEILING SERIES

C600TT • C800TT

SPEAKER PLACEMENT

Before installing your speakers, you should consider their placement carefully, taking into account the location of electrical, plumbing and other fixtures. Contact your Dealer for assistance if you are unsure of the best location for your particular listening environment.

Placement In Ceiling: When placing your speakers into the ceiling, they should ideally be located above the primary listening area. If the speakers are positioned far away from the primary listening area, adjust the pivoting tweeters so they are pointed towards it.

Note: To avoid possible damage to the pivoting tweeters, read the section entitled "SPEAKER ADJUSTMENTS" in this manual prior to performing the tweeter adjustment.

In a very large room with high ceilings, it may be necessary to place additional speakers throughout the room. Contact your Proficient Audio Systems Dealer for assistance.

MOUNTING SURFACE PREPARATION

New Construction - Unfinished Ceilings

A Pre-Construction Bracket, available from your Dealer, may be installed prior to drywall application across joists (up to 24" on-center) where a speaker will be located. After the hole is cut and the drywall is installed, the speakers are then easily installed following the instructions for mounting in "Finished Ceilings" below. **Note:** If the speakers are to be mounted more than 24" on-center, a special "Extra Long Wing" is available from your Dealer.

Finished Ceilings

Prior to the actual installation of the speakers, it will be necessary to run cables to the speaker locations. See your Dealer for more information about cable installation. After the cable has been properly installed, you are ready to mount the speakers. Following the simple steps listed below will result in a professional looking installation:

1. Determine the best area to mount your speakers. This area of the ceiling should be free of obstructions such as electrical conduit, HVAC ducts, or water lines. This can best be determined by noting the placement of fixtures and gaining access to an attic or crawl space for further analysis of the location of such obstacles.
2. Find the joists nearest the desired speaker mounting location. We highly recommend using a good stud-finder tool for this procedure. If you are lining up the speakers to some other object or molding in the room, make sure you consider the size of the baffle flange which extends beyond the mounting hole.

3. Mark the hole. A template for setting the hole is provided in the box (along with two paint mask inserts for use when painting). Position the template in the desired position and pencil an outline on the ceiling.

4. Cutting the hole. **CAUTION: This is the most important part of the entire installation.** If you are not certain whether any obstructions exist behind the desired mounting area, you should start by cutting a small hole in the center of your penciled mounting hole with a drywall saw, cutting at a 45° angle towards the inside of the hole. (See Diagram 1) Cutting the small hole at this angle will make drywall repair much easier, using the piece cut out. Once you have determined that there aren't any obstructions in your desired mounting location, start cutting the finished hole at a 90° angle to the ceiling surface.

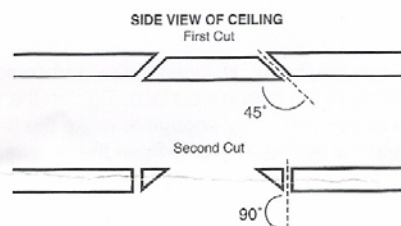

Diagram 1:
Ceiling Cut Out

5. Add insulation. If the area in the ceiling is not already insulated, add an adequate amount insulation material to loosely cover the back of the speaker. If the insulation material used is faced with foil or paper, position the foil or paper away from the speaker.

SPEAKER ADJUSTMENTS

The Ceiling Series speakers come from the factory with the tweeter facing straight out from the baffle. This will result in the overall smoothest response. However, depending on your particular primary listening area, room acoustics, ceiling height, or personal preference, you may find the sound more pleasing by pointing the tweeters in a particular direction. If additional treble is desired in the primary listening area, point the tweeter towards that area; and if less treble is required, point the tweeter away. Push gently at the edge of the tweeter to point it in the desired direction. (See Diagram 2) **CAUTION: Avoid touching metal dome tweeters, as damage may occur (C800TT).**

Diagram 2:
Tweeter

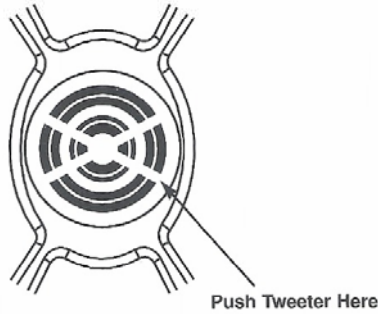

Tweeter Adjustment (C800TT):

The switch labeled TREBLE allows for 3dB of treble adjustment. Your speakers were shipped with the treble switch in the "-" position, providing the most linear frequency response. If you desire more treble, move the switch to the "+" position, and the tweeter will play 3dB higher. To return to the neutral setting, push the switch back to the "-" position. (See Diagram 3)

Woofer Adjustment (C800TT):

The switch labeled BASS allows for 3dB of bass adjustment. Your speakers were shipped with the bass set to "-". This setting provides the flattest bass frequency response. If you desire more bass, push the switch to the "+" position and the bass will play 3dB higher. To return to the neutral setting, push the switch back to the "-" position. (See Diagram 3)

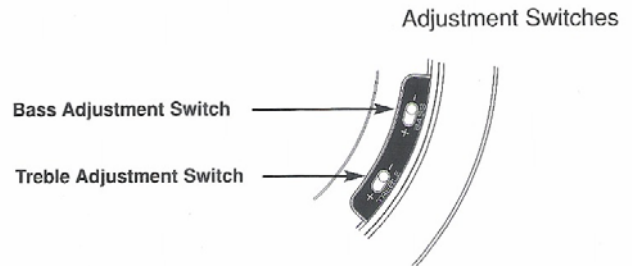

SPEAKER INSTALLATION

The unique integral four-foot mounting system incorporated into each Ceiling Series speaker allows for a quick installation by following these easy steps:

1. Remove the grille. It may be necessary to push one or two of the mounting screws and its attached foot towards the baffle and against the inside surface of the grille to force the grille out of its retaining groove.
2. Attach the speaker cable (observing the proper polarity with your amplifier, + to + and - to -). Either channel may be attached to either terminal set, however, be sure that polarity (+ and -) is correct on each channel or the performance of the speaker will be seriously affected, as one channel will cancel out the other. (See Diagram 4)
3. Make sure the mounting feet are turned inward to clear the opening, and insert the speaker into the ceiling. Position the speaker into the hole.

Note: The flange of the speaker is designed to flex and conform to any small imperfections in the ceiling's surface. Tighten the four screws on the front of the baffle only enough to make the flange become snug against the ceiling. As you tighten the screws, the feet will automatically flip into an outward position (See Diagram 5), thereby clamping the drywall between the feet and the flange.

CAUTION: Over-tightening may warp the baffle, crack the ceiling, cause the flange to distort, and make the grille difficult to install.

4. Push the grille firmly into the slot in the speaker baffle.

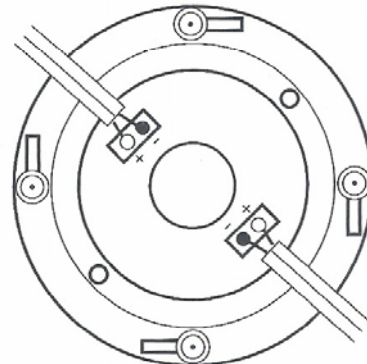

Diagram 4:
Correct Polarity

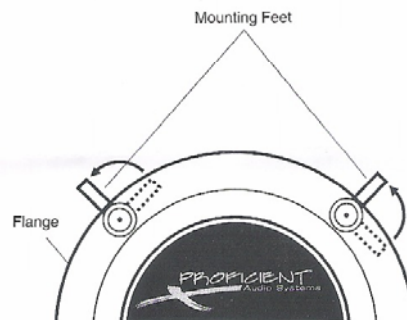

Diagram 5:
Mounting Feet

PAINTING THE SPEAKERS

If you plan to paint your speakers, we recommend that it be done prior to installation. If you plan to paint your speakers sometime in the future, it is best to remove them by simply reversing the steps for "SPEAKER INSTALLATION" above.

If it is necessary to paint the speakers when they are in the ceiling, the paint masks provided in the carton must be installed between the grille and flange while they are being painted with the ceiling.

Before painting your speakers, remove the white acoustic blanket under the grilles. Once the speakers have been painted, return the acoustic blanket back into place.

Great care should be taken not to clog the holes of the grille, as this will reduce the sound quality of the speakers.

Proficient recommends only light spray painting using 5 parts thinning agent to 1 part paint.

LIMITED TEN-YEAR WARRANTY

Proficient Audio Systems warrants to the original retail purchaser **only** that this product will be free from defects in materials and workmanship for a period of ten years, provided the speaker was purchased from a Proficient Audio Systems Authorized Dealer.

Defective products must be shipped, prepaid and insured, together with proof of purchase, to the Proficient Audio Systems Authorized Dealer from whom they were purchased, or to Proficient Audio Systems at the address listed on this installation instruction manual. Freight collect shipments will be refused. It is preferable to ship this product in the original shipping container to lessen the chance of transit damage. In any case, the risk of loss or damage in transit is to be borne by the purchaser.

If, upon examination at the Factory or Proficient Audio Systems Authorized Dealer, it is determined that the unit was defective in materials or workmanship at any time during this warranty period, Proficient Audio Systems or the Proficient Audio Systems Authorized Dealer will, at its option, repair or replace this product at no additional charge, except as set forth below. If this model is no longer available and can not be repaired effectively, Proficient Audio Systems, at its sole option, may replace the unit with a current model of equal or greater value. In some cases where a new model is substituted, a modification to the mounting surface may be required. If mounting surface modification is required, Proficient Audio Systems assumes no responsibility or liability for such modification. All replaced parts and product become the property of Proficient Audio Systems. Products replaced or repaired under this Warranty will be returned to the original retail purchaser, within a reasonable time, freight prepaid.

This Warranty does not include service or parts to repair damage caused by accident, disaster, misuse, abuse, negligence, inadequate packing or shipping procedures, commercial use, voltage inputs in excess of the rated maximum of the unit, or service, repair or modification of the product which has not been authorized or approved by Proficient Audio Systems. This Warranty also excludes normal cosmetic deterioration caused by environmental conditions. This warranty will be void if the Serial Number on the product has been removed, tampered with or defaced.

This Warranty is in lieu of all other expressed warranties. If the product is defective in materials or workmanship as warranted above, the purchaser's sole remedy shall be repair or replacement as provided above. In no event will Proficient Audio Systems be liable for any incidental or consequential damages arising out of the use or inability to use the product, even if Proficient Audio Systems or a Proficient Audio Systems Authorized Dealer has been advised of the possibility of such damages, or for any claim by any other party. Some states do not allow the exclusion or limitation of consequential damages, so the above limitation and exclusion may not apply.

All implied warranties on the product are limited to the duration of this expressed Warranty. Some states do not allow limitation on the length of an implied warranty. If the original retail purchaser resides in such a state, this limitation does not apply.

SPEAKER SPECIFICATIONS

	C600TT	C800TT
Speaker Type:	2-Way Coaxial In-Ceiling	2-Way Coaxial In-Ceiling
Tweeter:	Two ½" Polyamide Dome	Two pivoting 1" Aluminum Dome
Woofer:	6½" Injection Molded Polypropylene Cone with Dual Voice Coil and Rubber Surround	8" Injection Molded Graphite Cone with Dual Voice Coil and Rubber Surround
Impedance:	8Ω	8Ω
Sensitivity:	92dB 1W/1m	92dB 1W/1m
Frequency Adjustments:	None	Front-Mounted 2 Position +3dB Treble Adjustment Switch & +3dB Bass Adjustment Switch
Frequency Response:	36Hz - 20kHz	28Hz - 22 kHz
Power Recommendations:	5 - 100 watts (undistorted)	5 - 150 watts (undistorted)
Diameter x Depth:	9¼" x 3¾"	11¼" x 4¼"
Ceiling Cut Out:	8¼"	9¾"

In our attempt to constanly improve our products, features and specifications are subject to change without notice.

For technical inquiries please call 800.448.0876 or email us at techsupport@proficientaudio.com. We are available to assist you every weekday, except holidays, between the hours of 7:00 a.m. and 5:00 p.m. PST.

 **PROFICIENT**[™]
Audio Systems
940 Columbia Avenue, Riverside, CA 92507
800.448.0876 • Fax 909.787.8747 • proficientaudio.com