

STATUS Brightness

Diagram 3 also shows how an external resistor can be added to reduce the brightness of the Status LEDs on Proficient IR Receivers to any desired level.

In this example, an IR Power Supply–200mA is used as the voltage source to indicate the ON/OFF status of an A/V Receiver.

Choose a resistor value that achieves the brightness you desire (about 2.2k to 12k, 1/8 W). Connect it in series with the STATUS lead on each IR receiver desired, as shown.

IR Terminal

Use this unit to interface between the quad (4-circuit) plug on Proficient IR Receivers (so equipped) and 4-conductor home runs. This eliminates the need to cut off the plug and strip and tin the leads for certain applications. (See Diagrams 3 & 4)

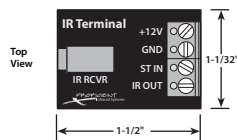

Diagram 4

LIMITED 5-YEAR WARRANTY

Proficient warrants to the original retail purchaser only that this Proficient product will be free from defects in materials and workmanship, for a period of 5-years, provided it was purchased from a Proficient Authorized Dealer. Defective products must be shipped, together with proof of purchase, prepaid insured to the Proficient Authorized Dealer from whom they were purchased, or to the Proficient factory at the address listed on this installation instruction manual. Freight collect shipments will be refused. It is preferable to ship this product in the original shipping container to lessen the chance of transit damage. In any case, the risk or loss or damage in transit is to be borne by the purchaser. If upon examination at the Factory or Proficient Authorized Dealer it is determined that the unit was defective in materials or workmanship at any time during this warranty period, Proficient or the Proficient Authorized Dealer will, at its option, repair or replace this product at no additional charge, except as set forth below. If this model is no longer available and can not be repaired effectively, Proficient, at its sole option may replace the unit with a current model of equal or greater value. In some cases where a new model is substituted, a modification to the mounting surface may be required. If mounting surface modification is required, Proficient assumes no responsibility or liability for such modification. All replaced parts and product become the property of Proficient Products replaced or repaired under this warranty will be returned to the original retail purchaser, within a reasonable time, freight prepaid. This warranty does not include service or parts to repair damage caused by accident, disaster, misuse, abuse, negligence, inadequate packing or shipping procedures, commercial use, voltage inputs in excess of the rated maximum of the unit, or service, repair or modification of the product which has not been authorized or approved by Proficient. This warranty also excludes normal cosmetic deterioration caused by environmental conditions. This warranty will be void if the Serial number on the product has been removed, tampered with or defaced. This warranty is in lieu of all other expressed warranties. If the product is defective in materials or workmanship as warranted above, the purchaser's sole remedy shall be repair or replacement as provided above. In no event will Proficient be liable for any incidental or consequential damages arising out of the use or inability to use the product, even if Proficient or a Proficient Authorized Dealer has been advised of the possibility of such damages, or for any claim by any other party. Some states do not allow the exclusion or limitation of consequential damages, so the above limitation and exclusion may not apply. All implied warranties on the product are limited to the duration of this expressed warranty. Some states do not allow limitation on the length of an implied Warranty. If the original retail purchaser resides in such a state, this limitation does not apply.

IR Mini Receiver with IR Terminal

The IR Mini Receiver is designed to be mounted on flat surfaces in furniture recesses, under shelves, etc., using the double-sided tape supplied. Among its unique features is an exclusive Ambient Noise Suppression (ANS) system. It acts to push down IRI, CFL, EMI, or ESI noise sources so that stronger signals from IR remotes have adequate margin for command of the controlled component.

Note: The ANS will take a few seconds to adjust to a given noise source. During this time, the blue Activity LED will glow brightly and then fade out. If the interference disappears momentarily, then returns, the fade down process will repeat. Certain noise sources, however, (such as Plasma Screens) may result in low-level flickering even after the fade down. This is normal. Such signals have been acted upon by the ANS, allowing most equipment to be controlled.

Diagram 1

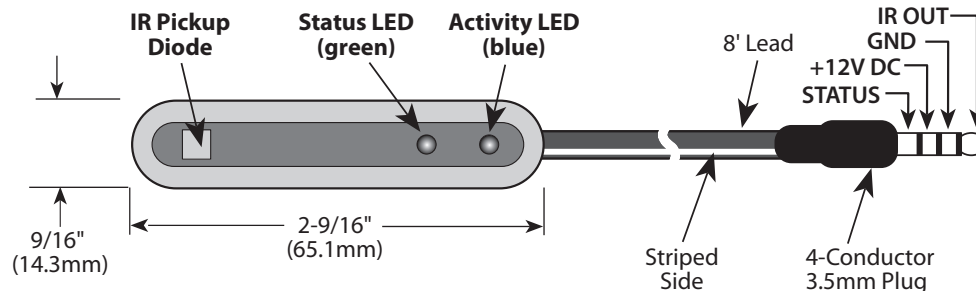

FEATURES/SPECIFICATIONS

- The IR Mini Receiver has a unique 3.5mm quad plug for direct plug-in to the Proficient IR Hub. It accommodates STATUS as well as IR, Power and Gnd connections.
- Exclusive Ambient Noise Suppressor (ANS) system.
- STATUS Indicator: Green LED for System On/Off indication.
- ACTIVITY Indicator: Blue LED indicates IR signal activity in a completed circuit with an IR Hub or an IR Flasher.
- Requires IR Power Supply, IR Hub and IR Flashers for IR repeater operation.
- Mounting: Attaches to any flat surface using the included double-sided tape. The tape may be applied to the back, top, or bottom surfaces of the IR Mini Receiver to accommodate the installation.

- Power: 12V DC @ 6 mA. Supplied from connected IR Hub.
- IR Lens rejects visible light interference.
- Crosshatch Shield (internal) inhibits EMI/ESI Interference.
- Carrier Frequency Acceptance Range: 28 to 90 kHz.
- Control Range: Up to 35 feet, depending on remote strength and ambient noise conditions.
- Control Angle: $\pm 50^\circ$ off axis.
- Dimensions (L x W x D): $2\frac{3}{16}$ " (65mm) x $\frac{9}{16}$ " (14mm) x $\frac{1}{2}$ " (13mm).

SYSTEM CONNECTIONS

The following are a few typical applications of the IR Mini Receivers for IR repeater systems.

A Basic System

Diagram 2 shows a basic plug-and-play installation, such as controlling components that are behind closed cabinet doors or in a nearby closet.

Diagram 2

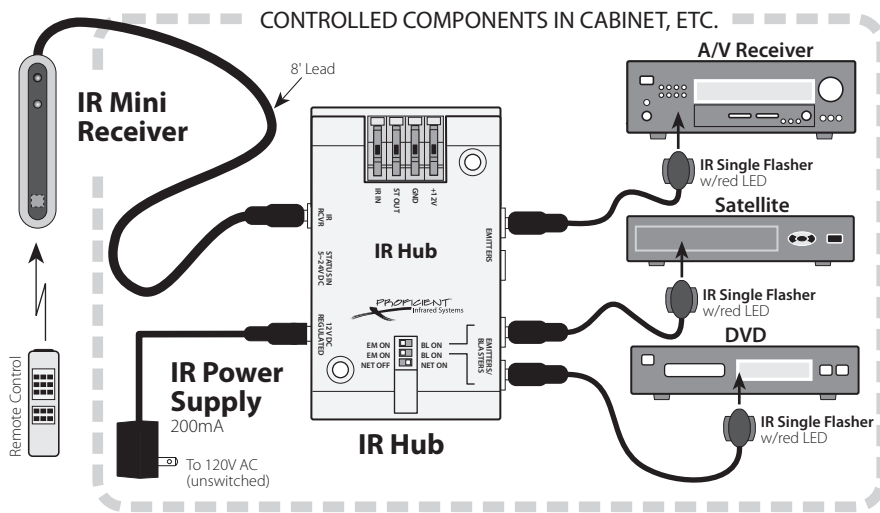

1. Mount the IR Mini Receiver in a recessed cabinet area or under a shelf, using the two-sided adhesive tape supplied.
2. Plug the IR Receiver and IR Flashers into the Proficient IR Hub, as shown.
3. Set the DIP switches on the IR Hub to EM ON and NET ON or OFF.
4. Plug in the IR Power Supply.
5. The remote control, fired at the IR Mini Receiver, should now control the components.

A Multi-Room System

Diagram 3 is an example of the IR Mini Receiver in a multi-room system with other Proficient IR receivers in various rooms, plus a local IR Mini Receiver. These control the various components in the main room or equipment area.

Diagram 3

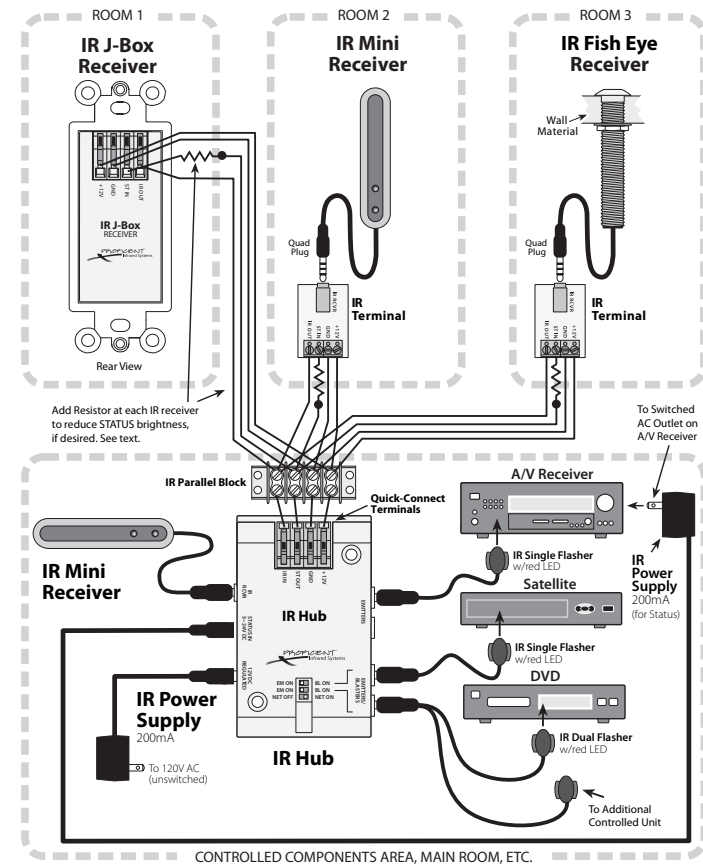

1. Pull 4-conductor wire from each room (home runs) to the IR Hub near the controlled components. **Note:** Use 24 gauge unshielded solid or stranded copper wire up to 1200' (Cat. 5e ok), 22 gauge up to 2000', 20 gauge up to 3000' and 18 gauge up to 5300'. **Total lengths include all wire runs from each room added together, not just the longest single run.** If using shielded wire, these lengths would be reduced by approximately 30%. Also, to achieve operation with long lengths, the lower DIP switch on the IR Hub must be set to the NET ON position.
2. Connect IR receivers in each room to the 4-conductor home runs as shown, using the IR Terminals supplied.
3. Connect the home run wires to the correct Quick-Connect Terminals on the IR Hub. **Note:** You may use the IR Parallel Block included with the IR Hub to help connect the many paralleled home run wires to the IR Hub's Quick-Connect Terminals.
4. Install and plug the various IR Flashers into the IR Hub.
5. Set the DIP switches to EM ON (or BL ON if using Blasters behind closet doors) and NET ON.
6. Plug the local IR Mini Receiver into the IR RCVR jack.
7. Plug in the IR Power Supply—200mA into the 12V DC Regulated jack.
8. A remote control, fired at the IR receivers, should now control the components.

Note: Refer to the Proficient IR Hub manual for Power Supply considerations.